

Fold on the dotted line - Place against door stop.

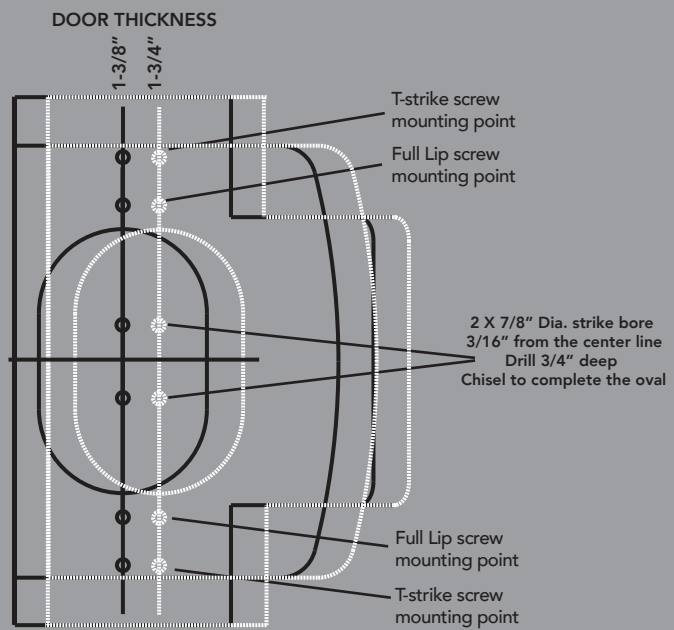

DOOR THICKNESS

1-3/4"

1-3/8"

T-strike screw mounting point
Full Lip screw mounting point

Full Lip screw mounting point
T-strike screw mounting point

2 X 7/8" Dia. strike bore
3/16" from the center line
Drill 3/4" deep
Chisel to complete the oval

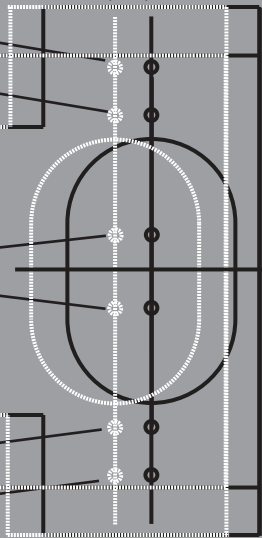

Fold on the dotted line — Place against door stop.

LATCH AND STRIKE TEMPLATE

FACE BORE

2-3/4" BACKSET

2-1/8" dia. cylindrical face bore

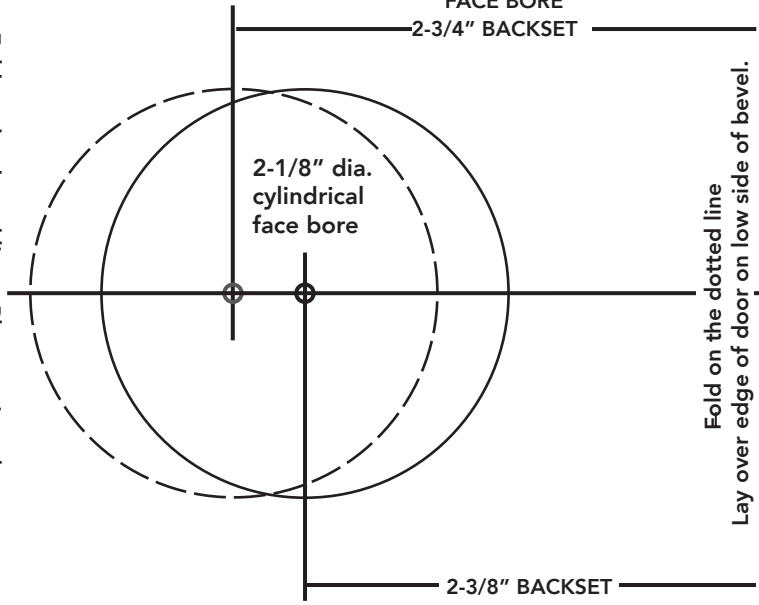

EDGE BORE

DOOR THICKNESS

1-3/8"

1-3/4"

SCREW MOUNTING POINTS

1" DIA. EDGE BORE

SCREW MOUNTING POINTS

Fold on the dotted line
Lay over edge of door on low side of bevel.

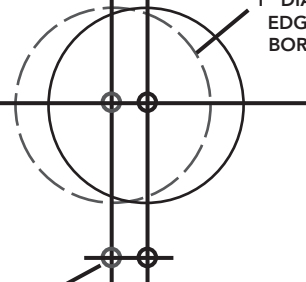

2-3/8" BACKSET

Copyright © 2023 ASSA ABLOY

Americas Residential Inc. All rights reserved